



**BSL Series**

## B-LFP24-100

**For Lead Acid, GEL or AGM**



### PRODUCT FEATURES

Designed for your solar, RV and marine applications, BSLBATT's 24V 2560 Wh lead reformed battery lasts four times longer than lead-acid batteries and is maintenance-free, lightweight and simple to operate.

Our B-LFP24-100 is equipped with the industry's leading brand of LFP batteries, the safest lithium battery chemistry available today. So it's ideal for deep cycle applications such as trolling motors, RVs or boating that require large amounts of power for long periods of time.

### CHARGE AND DISCHARGE CURVE

25.6V 100Ah Charge-Discharge Curve 0.2C, 25 C

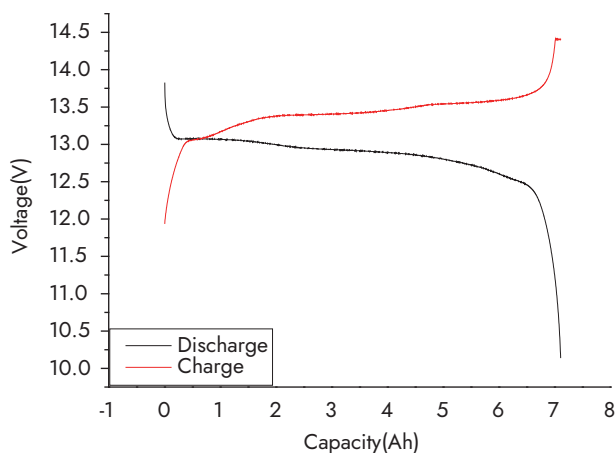

### DIMENSION

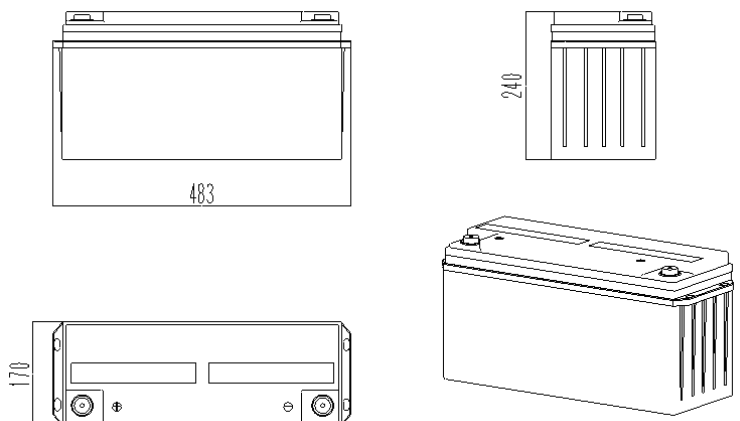

## Battery Model

**B-LFP24-100**

|                  |   |
|------------------|---|
| Nominal Voltage  | 25.6 V                                  |
| Typical Capacity | 100 ± 1.5 Ah ( At 0.2C discharge rate ) |
| Energy           | 2560 Wh                                 |

### Discharge

|                 |            |
|-----------------|------------|
| Working Current | 0.5 C      |
| Maximum Current | 1 C        |
| Cut-off Voltage | About 20 V |

### Charge

|                          |   |
|--------------------------|---|
| Voltage                  | 28.8 ± 0.2 V                              |
| Working Current          | 0.5 C                                     |
| Max Charging Current     | ≤ 1 C                                     |
| Charge Mode              | CC/CV, please use special lithium charger |
| Charging Cut-off Current | About 5 A                                 |

### Operation Temperature

|           |               |
|-----------|---------------|
| Charge    | 0°C ~ +55°C   |
| Discharge | -20°C ~ +60°C |

### Additional Data

|                              |  |
|------------------------------|--|
| Storage Temperature          | -20°C ~ +45°C  |
| Discharging Inner Resistance | ≤ 60 mΩ  |
| Protection Function          | Overcharge, over-discharge, over-current, short circuit and other protection functions |
| Output Mode                  | M8 Terminal  |
| Shell Material               | ABS  |
| Weight                       | Approx 19 Kg ( Single weight )   |
| Dimension ( L*W*H )          | 483*172*240 ( ±2 ) mm  |
| Modules In Series            | 2  |
| Cycle                        | ≥3500, 80%DOD ( 0.2C, 25°C )   |

Note: Parameters can be adjusted according to customer requirements



Facebook



Linkedin

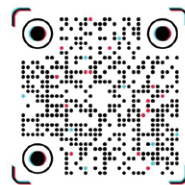

Tiktok



Instagram



Youtube



Drop-in Replacement



Tier One, A+ LiFePO4 Cell Composition



5 Years Warranty Guarantee



Smart Hardware & Software Design



Long Service Life



Eco-Friendly